



Loudspeakers are an extremely important part of your in car entertainment system and as such should not be overlooked. A loudspeaker that is potentially in excess of thirty years old is not likely to perform adequately or cope with the output of a modern radio. By replacing your loudspeakers you can be assured of a significant improvement in sound quality. We have a number of loudspeaker options available that suit most British and European cars.

Our **Single Voice Coil (SVC)** loudspeakers are suitable for cars with two speaker positions i.e. one position in both doors or one position on both sides of the car dashboard, or in the kick panels etc. These loudspeakers are supplied with a plain black mesh grille and can be installed with or without the grille.

Our **Dual Voice Coil (DVC)** Loudspeakers are suitable for cars that have a single aperture or grille in the dashboard, console or rear parcel shelf and they allow you to install a stereo loudspeaker in a position that was originally designed for a mono loudspeaker. These loudspeakers are supplied without a grille (although you can order these under a different part number if required).

All our loudspeakers offer high power handling and finely tuned acoustics to guarantee a well balanced sound.

## 4" (100mm)

## Co-axial loudspeakers SVC

Supplied in pairs. Part no. CS011

Impedance 4 ohms • Nominal 25 watts • Maximum 50 watts

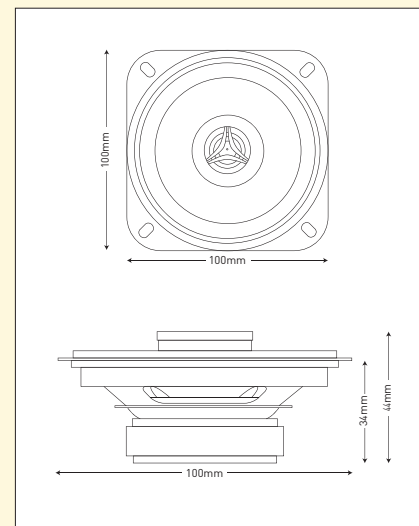

## 5¼" (130mm)

## Co-axial loudspeakers SVC

Supplied in pairs. Part no. CS012

Impedance 4 ohms • Nominal 30 watts • Maximum 60 watts

